

07-D024-22-880
September 1980

Supersedes
07-D024-21-880

PIRANI GAUGE HEADS

<u>Type</u>	<u>Code</u>
PR10-K	07-D024-22-000
PR10-C	07-D024-23-000
PRCT10-K	07-D021-52-000
PRCT10-C	07-D021-53-000
PRCT10-K Corrosion Resistant	07-D021-56-000
PR25-K	07-D021-64-000
G5C2	07-D022-11-000

Communication with Edwards

Any communication relating to the subject of these instructions should be addressed to Edwards High Vacuum or to the supplier from whom it was purchased.

Please specify:

- 1 The model, serial number and code
- 2 The date of purchase
- 3 Your order number and the suppliers sales reference

Equipment should not be returned to the supplier without prior arrangement

Damage in transit

If any damage has occurred in transit, it is important to inform both the carrier and the supplier within three days of delivery.

Edwards High Vacuum

Manor Royal, Crawley, West Sussex RH10 2LW, England
Telephone: Crawley 28844 (std code 0293) Telex: 87123 Edhivac G

© Printed in England P158 Edwards High Vacuum is part of BOC Limited

1 Vacuum couplings

The size and type of the vacuum coupling are indicated by the numerals and final letter of the gauge head model number.

Size 10 = 10 mm (nominal)
 25 = 25 mm (nominal)

Type of coupling

K = KF

C = Cone, metal, B14 to BS 572:1960

Exception G5C2 is a glass gauge head with a B14 glass cone

Note: A range of vacuum connexions and pipeline components is available from Edwards, both KF and screwed. A full description appears in the Edwards catalogue.

2 Functionally equivalent types

Old type	New type	Used with
M6B M7B G6B	PR10-K PR10-C	Pirani 10 Pirani 11 Controller 101
M9 M12	PRCT10-K	Pirani 9 Pirani 12 Monitor 101 Controller 161
G12 M12 (UF6)	PRCT10-C PRCT10 Corrosion Resistant	Controller 162
M5C2	PR25-K	Pirani 8/2 Pirani 14
G5C2	G5C2	

3 Specification

		PR10	PRCT10	PRCT10 Cor.Res.	PR25	G5C2
Pressure (N ₂) range	mbar	5 to 10 ⁻³	100 to 10 ⁻³	100 to 10 ⁻³	1 to 10 ⁻⁴	1 to 10 ⁻⁴
Volume	cm ³	8	6.5	6.5	21	21
Dimensions (excluding lead)	mm	139 x 40 x 25.6			220 x 51 dia	194 x 51 dia
Weight	kg	0.27	0.14	0.19	0.58	0.31

Leads All heads are fitted with leads 2m long.

Extension leads

(available
to order)

Gauge head	Length	Code number
PR10	5m	07-D368-03-005
	15m	07-D368-04-015
	30m	07-D368-04-030
PRCT10 PRCT10 CR	5m	07-D368-05-005
	15m	07-D368-06-015
	30m	07-D368-06-030
PR25 G5C2	5m	07-D368-01-005
	15m	07-D368-02-015
	30m	07-D368-02-030

4 Connexion to vacuum system:

New installations

The gauge head should be mounted as close as possible to the point at which the pressure is to be measured, using a short branch tube with a diameter no less than the gauge head size. Long or narrow connexions can cause serious error.

The head should be positioned vertically so that the gauge body is above the connexion. If the gauge head is mounted in any other attitude, it may require a slight adjustment to the 'atm' pre-set, as described in Section 8, Maintenance.



The internal pressure of the G5C2 gauge head must not be allowed to exceed atmospheric pressure.

The internal pressures of the PR10, PR25 and PRCT10 gauge heads must not exceed 2 bar at 28°C.

Do not use the gauge head to measure the pressure of explosive or inflammable gas mixtures. The sensing elements operate normally at the following temperatures, PRCT10, 160°C (depending on ambient temperature) PR10/25 up to 300°C (depending on ambient temperature and pressure). It is possible that malfunction on momentary transients could raise the sensor above the ignition temperature of combustible mixtures which might then explode.

4.1 KF gauge heads

The branch tube should be fitted with a matching KF flange and assembled with the appropriate KF centring ring, O-ring and clamp.

Alternatively if the branch tube termination is screwed the clamp is replaced with an Edwards SC coupling nut of the correct size. The KF O-ring and carrier will be needed.

4.2 Cone fitting gauge heads

A borosilicate glass B14 cone (female) is supplied as an accessory for joining to the vacuum system.

5 Connexion to control unit

Plug the lead into the socket on the back panel of the control unit, with the optional extension lead if used.

The lead should always be cleated to secure supports.

For cone-coupled heads, it is important to cleat the lead securely a short distance vertically above the gauge head to ensure that no strain is imposed on the cone coupling.

6 Description

The PR10 and PRCT10 gauge heads are all constructed in the same way. The body consists of a pair of identical rectangular mouldings, held together by four cross-head screws. These mouldings contain the Pirani tube and also clamp the lead and the vacuum coupling stub, one at each end of the body.

Adjusting and compensating resistors are also housed in the body of the PR10. They are pre-set in manufacture and should not normally be disturbed.

The PR25 and G5C2 heads use a tubular body into which the vacuum coupling stub and the end-piece supporting the lead are fixed by radial screws. The body contains the four Pirani tubes.

The internal electrical connexions are shown on page 7.

7 Maintenance

Gauge heads require no maintenance in normal service.

7.1 Contamination

Extended operation in a contaminating atmosphere or any gross contamination may change the gauge head calibration. If this is suspected, the recommended procedure is to return the gauge head to Edwards under the Edwards Exchange/Replacement service, but in an emergency an attempt may be made to wash out any Edwards gauge head except the PR25 and G5C2. There is no certainty of success.



Switch off the gauge control unit and unplug the gauge head before dismantling the head.

7.2 Washing out PR10 and PRCT10 gauge heads

Acetone is suggested as a first trial. Use 1 or 2 ml of pure acetone with very gentle agitation, repeat twice and allow to dry.

A proprietary solvent may be more effective. After using one, the gauge head should be rinsed thoroughly with distilled water, then with alcohol and finally blown dry.

Caution Acetone attacks the plastic case.

After washing a gauge head, it is advisable to check the calibration, as described below for the PR10 and as described in the instructions supplied with the control unit for the PRCT 10.



Cleaning solvents such as trichloroethylene, perchlorethylene, toluene and acetone produce fumes that are toxic and/or inflammable. Such solvents should only be used in well ventilated areas away from electronic equipment or flame.

7.3 Calibration check, PR10

Replace the gauge head on the vacuum system and plug in its connector.

- 1 With the vacuum system at atmospheric pressure, note the instrument reading and if necessary adjust the 'set atm' pre-set on the gauge head to bring the meter to the 'atm' mark.
- 2 Pump down to 10^{-3} mbar, check the reading and if necessary adjust the 'set vac' pre-set.
- 3 Recheck 1 and 2.

If there is insufficient range of adjustment on either pre-set, the gauge head should be returned to Edwards under the Edwards Exchange/Replacement service.

Circuit diagrams

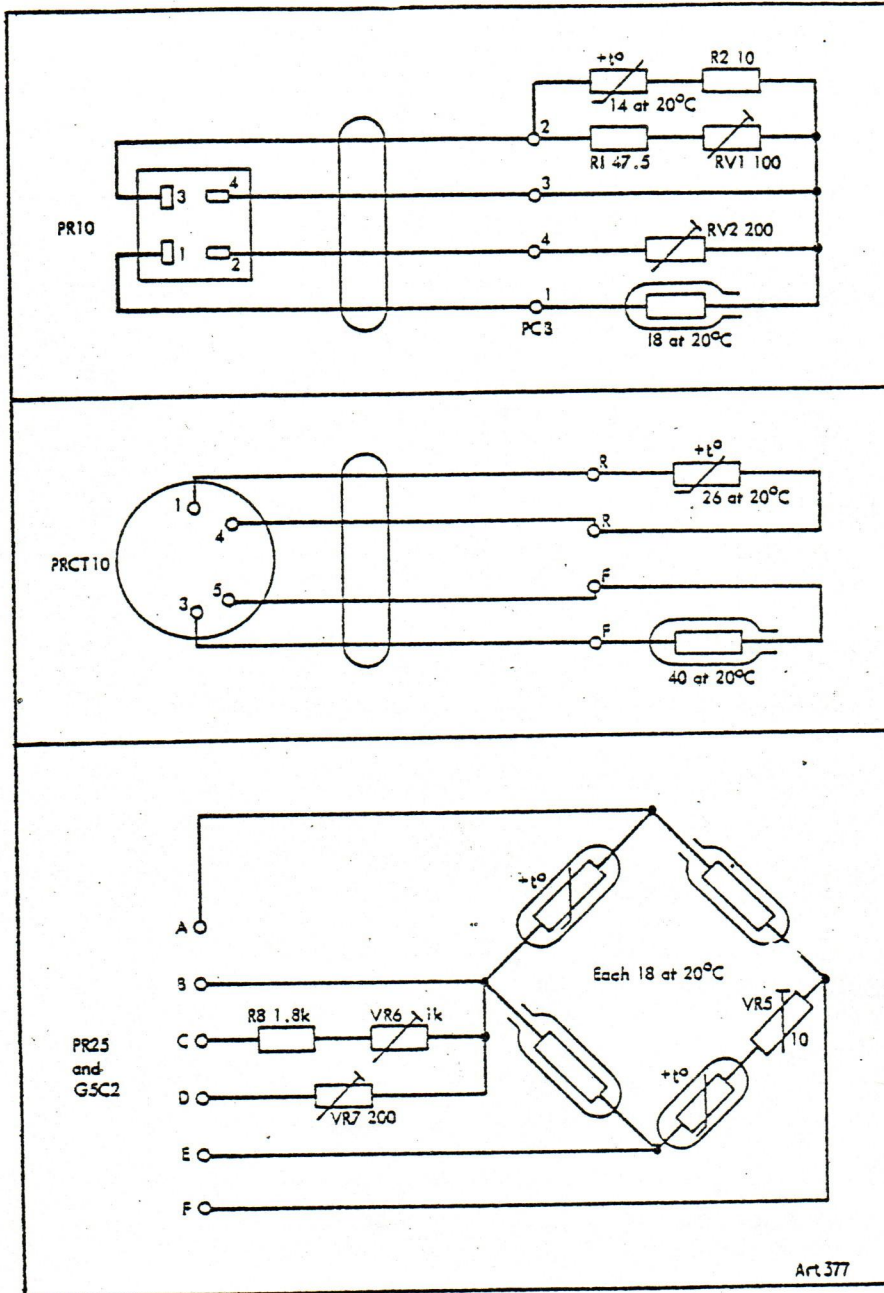

Communication with Edwards

Any communication relating to the subject of this instruction should be addressed to Edwards High Vacuum or to the supplier from whom it was purchased.

Please specify:

- 1) the model, serial number and code.
- 2) the date of purchase.
- 3) your order number and the suppliers sales reference.

Equipment should not be returned to the supplier without prior arrangement.

IMPORTANT Health and Safety

Under Section 3 of the Health and Safety at Work Etc Act 1974 every employer has a duty to conduct his business so as not to expose persons not in his employment to risks to their health and safety. When goods are returned to the supplier, therefore, warning must be given if their usage is likely to render the equipment hazardous in any way.

Edwards High Vacuum and its distributors reserve the right to refuse acceptance of any equipment returned which they have reason to believe may be hazardous.

Damage in transit

If any damage has occurred in transit, it is important to inform both the carrier and the supplier within three days of delivery.

07-D043-14-881
January 1980
Supersedes M07875

PENNING 8
VACUUM GAUGE
Code 07-D043-14-000

CONTROLLER 201
VACUUM GAUGE and SWITCH
Code 07-D361-48-000

COMMUNICATION WITH EDWARDS

Any communication relating to the subject of this instruction should be addressed to Edwards High Vacuum or to the supplier from whom it was purchased.

Please specify:

- 1) The model, serial number and code etc.
- 2) The date of purchase.
- 3) Your order number and the suppliers sales reference.

Equipment should not be returned to the supplier without prior arrangement.

Installation

The instrument as supplied is free standing; it can easily be rack mounted by means of an Edwards adaptor. The instrument cover should be left on.

Electrical power supply

Warning

Do not connect the instrument to the mains with the cover off. Lethal voltages (2.3 kV) exist within the instrument when switched on.

The gauge head supply voltage of 2.3 kV appears at the concentric head socket on the back panel. Do not unplug or plug in the head with the instrument switched on.

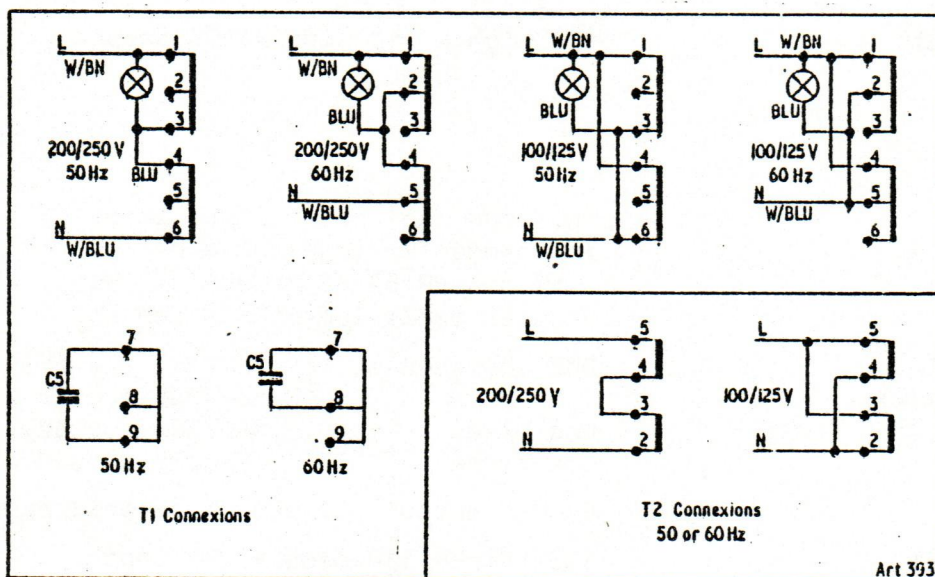

Figure 1. Mains transformer primary connexions

The instrument as delivered is ready for connexion to a mains supply of 200 to 250V, 50 Hz, 1 ph.

For any other voltage or frequency, the internal connexions must be altered. Remove the instrument cover and solder the leads to the mains transformer tags according to figure 1.

Connect the mains cable to a switched outlet. A good earth connection is required.

GAUGE HEAD

Plug the lead supplied with the head, or the extension lead if used, into the coaxial socket on the back of the instrument.

RECORDER

The recorder terminals on the back panel may be connected to a potentiometric recorder of 10 mV f.s.d. The recorder connexions must be isolated from earth and from other circuits.

The deflexion of the external recorder corresponds to the angular deflexion of the calibrated meter, irrespective of the setting of the range switch. Any change of range (while the instrument is switched on) is shown by a step in the record. Operation of the switching point setting controls of the Controller 201 also produces a characteristic trace.

PENNING 8

Control terminals link

Unless external apparatus is to be used, the terminals 'control +' and 'control -' on the back panel must be connected together.

CONTROLLER 201 : Control outputs

The diagram beside the terminal block on the back of the instrument shows the internal connexions to the contacts of the relay in the de-energized state, which occurs when the pressure is above the 'hi' switching point. The contacts change over when the pressure falls below the 'lo' switching point.

The relay contacts are isolated from the Controller 201 circuit and from earth. Connect the terminal block to the external apparatus to be switched, using the fanning strip provided.

For example, if the Controller 201 is required to protect the filament of the Edwards LT201 leak detector from exposure to too high a pressure, the 'make' contacts (open when de-energized), next to the recorder terminal block, should be wired to the 'vac protect' terminals of the LT201.

Slave relays must be used if the load imposed by the switched apparatus exceeds the contact ratings.

An auxiliary vacuum switch to protect associated apparatus from exposure to pressures at which the Penning gauge does not operate, that is above about 100 mbar, may be wired in series with the Controller 201 contacts so as to open the circuit at high pressures.

Operation

Switch on and select the range which gives an on-scale reading on the meter.

Note: If the pressure is above about 100 mbar, the Penning discharge will not strike, and a false reading of zero pressure will be given.

The meter is direct reading for air and dry nitrogen. For other gases, divide the meter reading by the following approximate correction factors:

Argon	1.4	Hydrogen	0.4
Carbon dioxide	1.6	Mercury vapour	2.7
Carbon monoxide	1.1	Neon	0.34
Helium	0.18	Water vapour	0.85 to 1.16

RECORDER CALIBRATION

The millinar calibration of the recorder is given by the curves of figure 2.

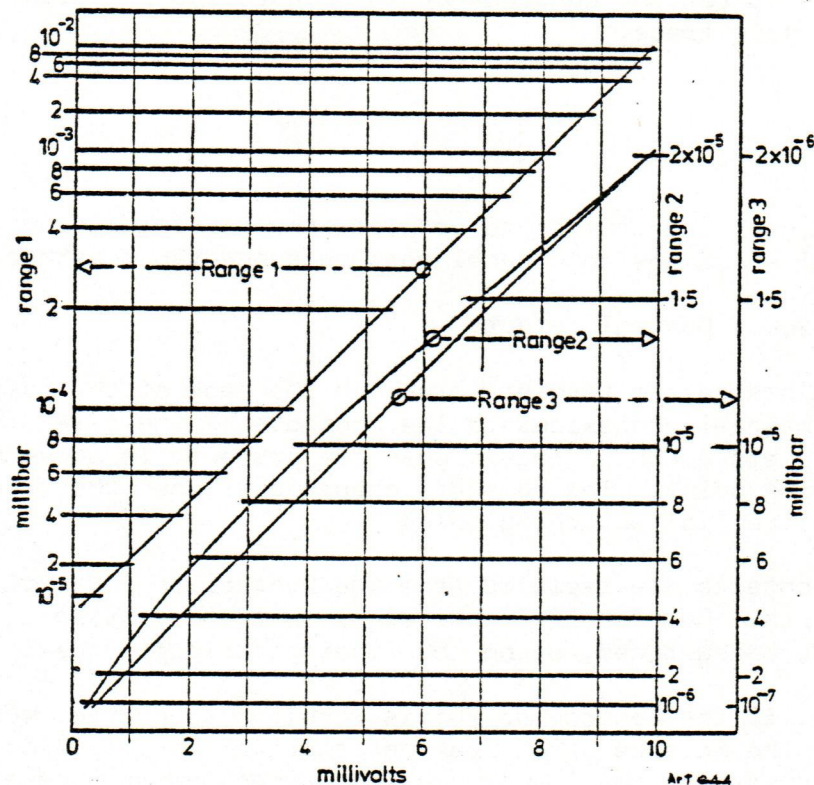

Figure 2 Recorder calibration Penning 8 and Controller 201

CONTROLLER 201

Setting the pressure switches

The lo-mbar-hi switch allows the lo and hi change-over points of the pressure-controlled relay to be set at any time; the setting operation is independent of the conditions in the vacuum system.

Pressure measurement is suspended while the switch is held in the 'lo' or 'hi' position and restored as soon as the knob is released and the spring loading returns the switch to 'mbar'.

The lo and hi operating points of the relay may be set, independently, over almost the whole pressure range of the instrument. The limits of setting are 0.5 and 99.5% of the meter (angular) full scale deflexion (f.s.d.) on whichever ranges are selected.

The hi switching point must be set at a higher pressure than the lo switching point, the minimum permissible difference being 1% f.s.d. If an attempt is made to set hi lower than lo, the relay will chatter and will not operate correctly.

To set the lo switching point, switch to the range which includes the required switching pressure, turn the lo-mbar-hi knob to the lo position and hold it there. Adjust the lo control, by means of the special screwdriver provided, until the meter indicates the pressure at which the switch is to operate. Allow the switch to return to 'mbar'.

Repeat the setting operation for the hi switching point.

From then on, the relay will change over at the set pressures; its operation is separate from the measurement of pressure (though it depends, of course, on the gauge head current). For example, if the lo point has been set to 10^{-4} mbar, the relay will be energized when the pressure falls through 10^{-4} mbar even though the range switch may be set to 2 or 3.

The state of the relay is shown by the red LED (light emitting diode) on the front panel which lights when the relay is de-energized, that is when the pressure is high.

Description

The instrument is a cold-cathode ionization gauge, a modern development of the system first described by F M Penning. The interior of the gauge head is open to the vacuum system and contains two metal electrodes which are connected to the supply of 2.3 kV dc. Electrons are drawn from the cathode and accelerated towards the anode, ionizing the gas molecules present, and producing a glow discharge. A permanent magnet produces a field of about 55 mT (550 gauss) in the ionization chamber. The field deflects the electrons so that they do not travel directly to the anode but follow a complex path whose length is much greater than the electrode spacing. The efficiency of ionization is correspondingly increased.

The ions travel to the electrodes and constitute the ionization current which is measured by the instrument.

At low pressures, the current increases with the number of gas molecules present, that is, with the pressure. At about 1 mbar, the current reaches a maximum value and then falls until, at about 100 mbar, the discharge ceases and the current falls to zero.

This behaviour, characteristic of the Penning discharge, must be borne in mind. It causes the gauge to give a false indication of a very low pressure when the real pressure is above about 100 mbar. It will also cause apparatus controlled by the pressure switches of the Controller 201 to operate wrongly unless additional protection is provided. The usual method is to use an auxiliary pressure switch, operating at an intermediate pressure below 100 mbar, to inhibit the Penning switch. Suitable Edwards auxiliaries include the Controller 101 combined Pirani gauge and pressure switch and the VSK1 capsule operated vacuum switch.

Circuit description

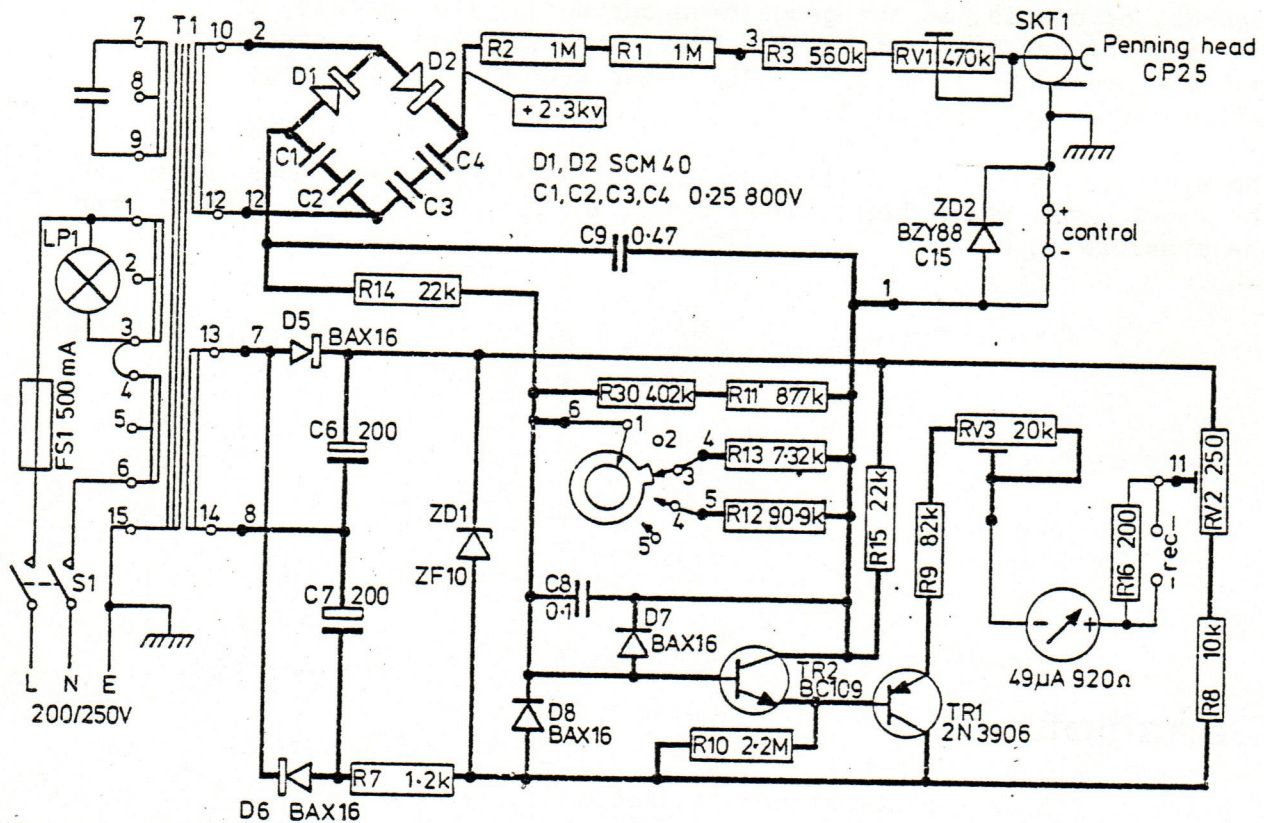

Figure 3 Penning 8 circuit

Art 641

PENNING 8

The current from the gauge head flows through the range resistor selected by the range switch S2 (S1b of the Controller 201). The current is amplified by TR1 and TR2 to operate the meter. The meter current also flows through R16 to produce a voltage suitable for a 10 mV potentiometric recorder.

In the Penning 8, the gauge head current also flows through the 'control' terminals, to which external apparatus may be connected. The Zener diode ZD2 protects the amplifier and the operator if the instrument should by mistake be switched on with the 'control' terminals disconnected.

The 2.3 kV gauge head supply appears at the 'head' socket when the head lead is unplugged. Since the source resistance is about $3M\Omega$, the socket is not lethal, but is capable of giving a painful shock.

CONTROLLER 201

The measuring amplifier circuit is the same as in the Penning 8 except that the gauge head current flows also through R20 and produces a voltage to operate the hi - lo relay. The voltage across R20 is compared by IC1 with the voltage on either the hi pre-set RV5 or the lo pre-set RV6. Relay A selects the pre-set, lo when de-energized (when the pressure has risen through the hi point) and hi when energized (when the pressure has fallen through the lo point).

When S2 is in its rest position, mbar, the IC output drives TR4, which operates RLA and drives TR3, which operates LED1, the red LED that lights when the relay is de-energized. RLA operates the contacts that are connected to TB1 on the back of the Controller.

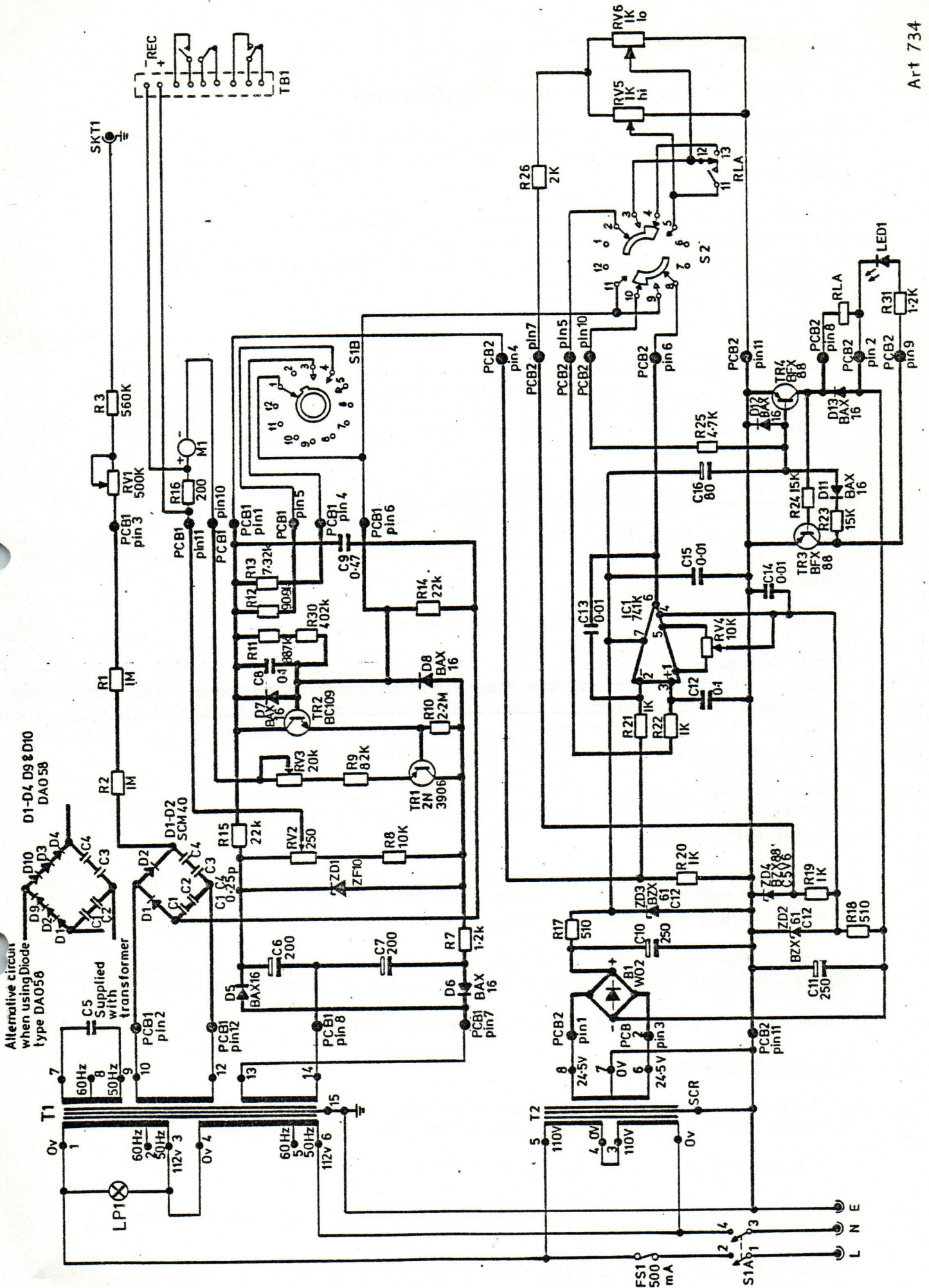

Alternative circuit when using Diode type DA058

Figure 4 Controller 201 circuit

Maintenance

The instrument normally requires no maintenance.

The recommended procedure for dealing with a fault on a printed wiring board is to replace the complete board and return the faulty one to Edwards for repair.

When the printed board 07-D043-14-010 is replaced, the pre-sets RV1, RV2 and RV3 should be re-adjusted as described below. If facilities for doing this are not available, it is recommended that the instrument be returned to Edwards for service.

Warning

Lethal voltages exist inside the instrument when it is connected to the mains. In addition to the mains voltage, there is the Penning gauge head supply at 2,300 V and the circuit includes capacitors charged to this voltage. Do not touch any internal part when the mains are connected.

Replacement of circuit board 07-D043-14-010

Switch off and disconnect from the mains.

Unplug the gauge head.

Remove the four screws securing the cover and lift off.

If the instrument has recently been switched on, make sure the high voltage capacitors C1 to C4 are discharged by short-circuiting pin 3 to the junction of C1 and D1. Use a well-insulated shorting link. It is best to leave the shorting link in position to dispose of the charge absorbed in the dielectric of the capacitors.

Release the clips holding the board. Remove the board and place it beside the instrument. Put the replacement board on top of the faulty board with the pins aligned.

Unsolder the wires one at a time and solder to the replacement board in the same position. Use a lower power (25 W) iron with a small (6 mm) bit, and non-corrosive flux.

Slide the new board into the guides and push the clips into position, making sure that the peg locates correctly in the hole in the board.

Adjust the three pre-sets, then replace and secure the cover.

Adjustment of pre-sets

1. Connect a resistor of 94 M Ω to the head socket in place of the gauge head. Set to range 1 and switch on.

Adjust RV2 to give a reading of 10^{-5} mbar.

2. Remove the resistor from the gauge head socket and connect in its place a resistor of 40.5 M Ω .

Switch to range 2 and adjust RV3 to give a reading of 2×10^{-5} mbar.

3. Replace the resistor by one of 720 k Ω .
Set to range 1 and adjust RV1 to give a reading of 10^{-2} mbar.